

LÜDECKE

Since 1930. The perfect connection.

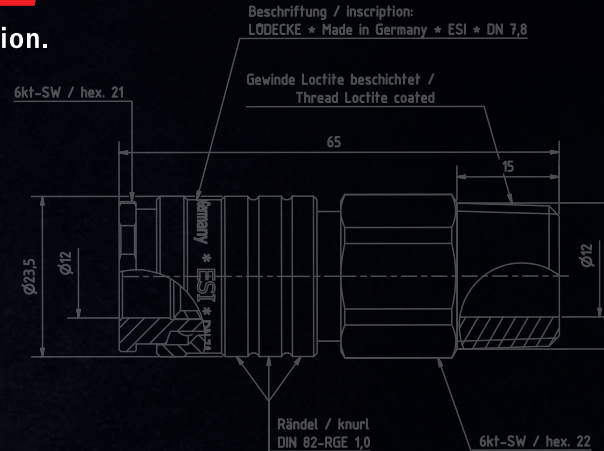

INDIVIDUAL SOLUTIONS
MADE IN GERMANY

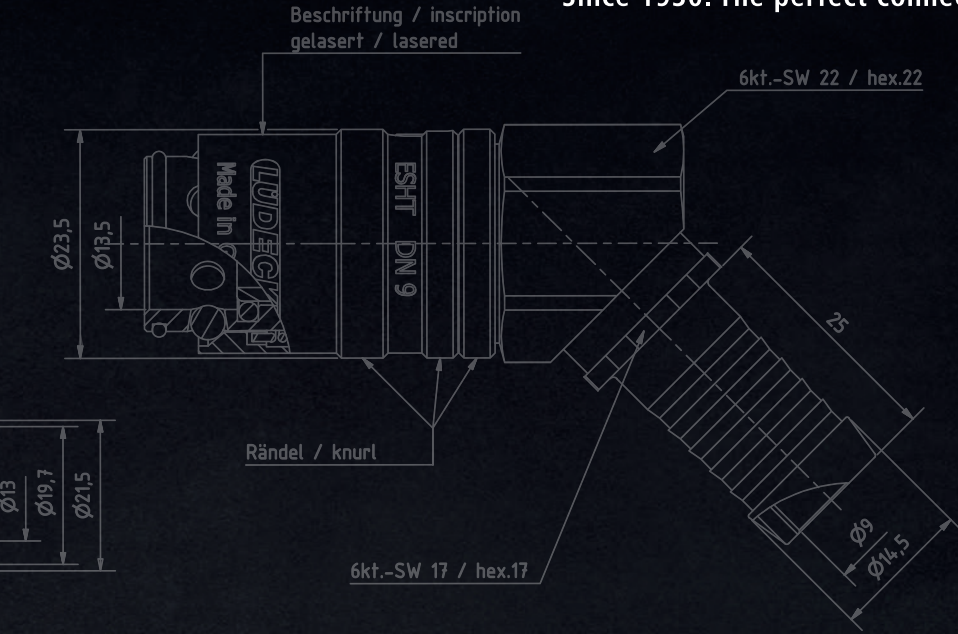

LUDECKE Engineering Expertise

Knowhow, innovation and performance:

This combination makes **LUDECKE** GmbH not only a specialist for coupling systems for connecting flexible media flow lines with tools, machines and systems - but also an ideal partner in the development and implementation of individual custom-made products.

At the Amberg location, we are producing high-quality, sophisticated and sustainable products for daily usage. In addition to the extensive standard program, we also manufacture individually designed custom-made items for different applications and media. These range from single products through complete systems to complex assemblies.

Each special project undergoes a structured and ideally coordinated development process. The goal is to deliver first-class and optimally adapted coupling systems, which are characterized by flawless functionality, longevity and at the same time a good eco-balance.

On the following pages, we give an overview of the chances and opportunities offered by working with the team of **LUDECKE** experts.

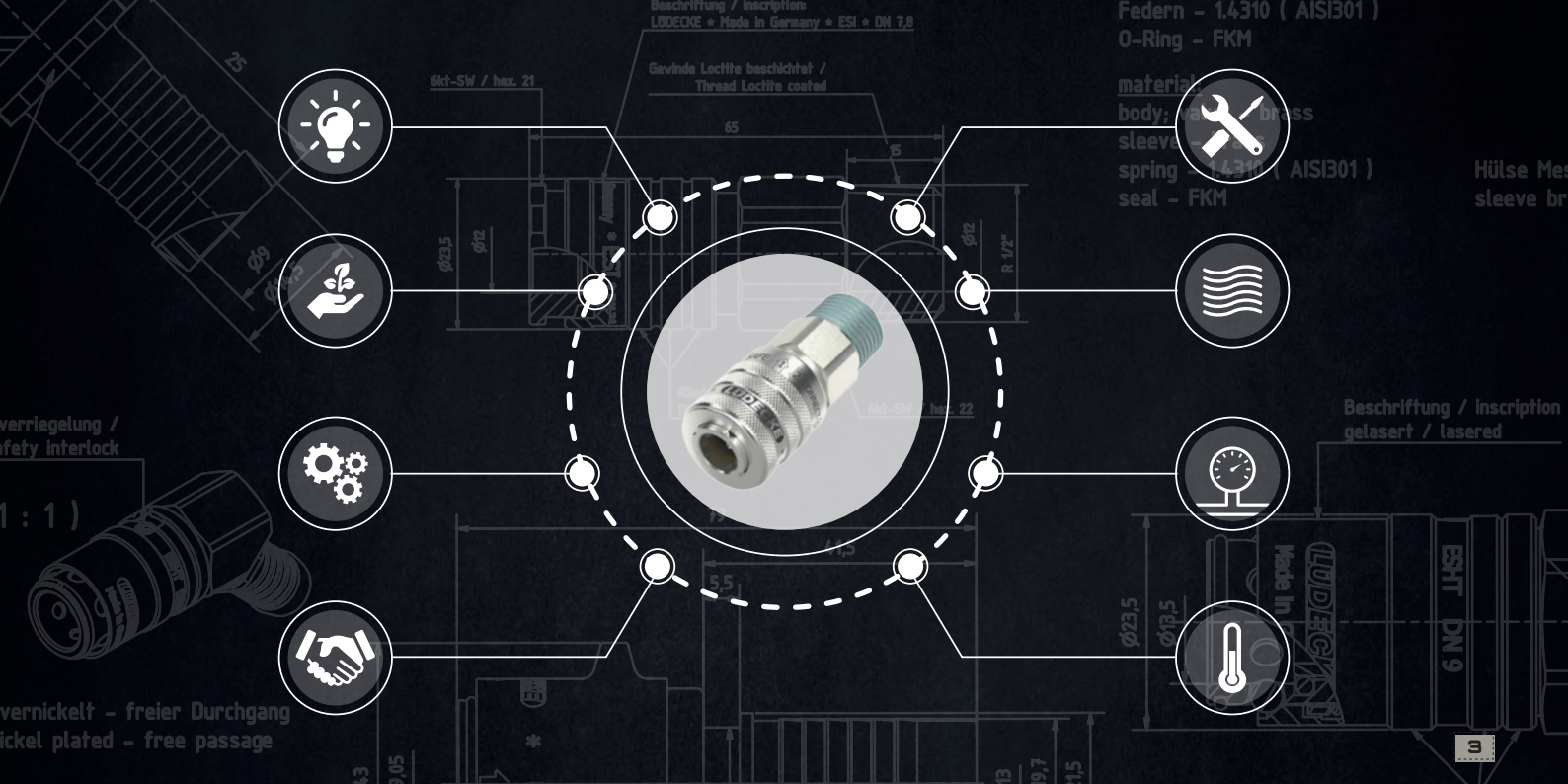

Verriegelung /
Safety interlock

1:1)

vernickelt - freier Durchgang
nickel plated - free passage

Beschriftung / inscription
LODECKE • Made in Germany • ESI • DN 7,8

Gewinde Lochfite beschichtet /
Thread Loctite coated

Federn - 1.4310 (AISI301)

O-Ring - FKM

material
body: brass
sleeve: 1.4310 (AISI301)
spring: 1.4310 (AISI301)
seal - FKM

Hülse Messing
sleeve brass

Beschriftung / inscription
gelasert / lasered



Applications

Our couplings and fittings are adapted to different applications.

Pneumatics	for compressed air applications
Temperature Regulation	for temperature regulation applications in the plastics processing industry
Construction Industry	for outdoor use in the construction sector
Processing Industry	for applications with specific hygienic requirements and/or for various critical media
Water Application	for water supply for professional or private use

Your idea cannot be found? Challenge us! We are happy to enter new territory.

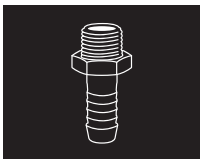

Branches

Due to the extensive range of services, the products of the **LUDECKE** GmbH are used in a wide range of industries:



Fluid Technology



Transport and Traffic



Pharmaceutical and Medical Engineering



Food Industry



Industry



Plastics Technology



Agriculture



Snowmaking Technology



Machinery and Equipment



Construction Industry



Gardening and Landscaping



Craftsmanship



Drive Technology



Municipal Technology



Server and Processor Cooling



Petrochemical Industry



Chemical Technology



Welding Technology



Development Process of an Individual Solution

We develop and produce a large number of high-quality couplings and fittings for our worldwide customer base. Our standard product range includes more than 30,000 products. If this range does not meet the requirements, we will develop an individual custom-made product in cooperation with you. We produce solutions of various sizes, valve types and technologies to ensure zero leakage, maximum flow and perfect operation.

The development of a special solution at **LÜDECKE** follows a proven and standardized process. Through this structured process, we guarantee fast, targeted and transparent project handling. Despite this predefined process, we place great importance on a dynamic development, that allows flexibly to adapt to changing conditions.

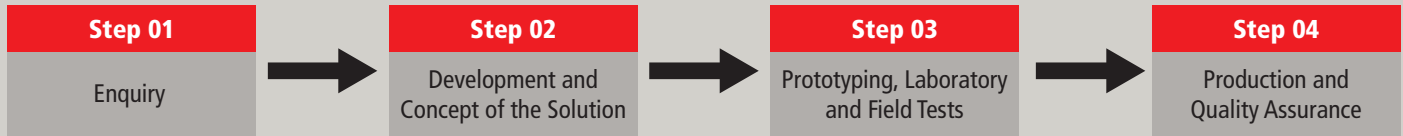





01. Enquiry

Once an enquiry for a specific special solution from a customer reaches us, the respective sales representative will contact the customer directly to communicate the exact specifications of the product.

To create the requirement profile, we need (as far as possible) a detailed information on the following criteria:

Media behaviour
<ul style="list-style-type: none">• Type of media• Pressure range• Temperature• Flow characteristics

Application
<ul style="list-style-type: none">• Industrial segment• Surrounding• Space• Handling

Miscellaneous
<ul style="list-style-type: none">• Assembly• Specifications• Others

The more accurate the communication is, and the more information we receive, the faster and precisely the targeted process of the development can begin.

Our sales and technical staff are prepared to go on location at any time to obtain an exact picture of the application and requirements.

Upon these initial, but significantly important steps, a pre-analysis takes place between sales and development staff, whether and by what means the requirements of the customer can be implemented.



✓ Practicability ✓ Potentials ✓ Improvements

02. Development and Concept of the Solution

Based on the requirements on the product, the performance-specific tasks and responsibilities are defined in a project team from the various internal departments. State-of-the-art software as well as short ways within the company and regular meetings guarantee goal-oriented work for the fast and efficient development of special solutions in top quality.

As a first step, the CAD design of the product is based on the requirement profile. This will be released by the **LUDECKE** project team after a comprehensive technical check. After internal approval, the customer receives the drawing for review.

Throughout the development process, a inter-company exchange regularly takes place, which is why we can react quickly and flexibly to possible changes or adjustments.





- ✓ Cooperation
- ✓ Flexibility
- ✓ Target orientation

PRODUKTION

ERING-DE



03. Prototyping, Laboratory and Field Tests

Upon completion of the design phase and drawing approval from the customer, and when technically necessary a prototype is ordered. The production of a prototype or prototype series is always coordinated with the development and the responsible sales representative.

Should the customer approve the prototype, detailed tests are carried out. This starts with various product tests in the **LUDECKE** test center.

Our specially trained specialists carry out pressure, bonding and temperature tests as well as other specific application tests. After that, the field tests begin. In the process, the product is critically examined over a certain time period and evaluated accordingly.

The whole testing phase is continuously monitored and documented in detail within the framework of an initial sample test report. If changes or improvements occur during the testing phase, they will of course flow into the development process.



- ✓ Efficient
- ✓ Durable
- ✓ Safe





04. Production and Quality Assurance

A successful test phase is immediately followed by series production.

LUDECKE uses the most advanced machine technology and has a broad spectrum of high-performance machinery and equipment according to the latest, up-to-date technology.

Through the complete in-house production, we can respond quickly and flexibly to the most diverse customer requirements and are able to permanently optimize and improve the products.

In order to meet our high-quality standards and to guarantee our customers first-class products at all times, regular quality controls are conducted during the ongoing serial production process. The corresponding test specifications are individually adapted according to the product and integrated into every step of the supply chain.

This is how we ensure a maximum of safety and customer service at all times.

At **LUDECKE**, the development process does not end with the completion of the custom-made product.

We offer our customers a first-class all-round service. We are always available as a competent partner and upon request, we are teaching our specific product knowhow in specially adapted training courses.



Rändel / knurl

6kt.-SW 17 / hex.17

Ø9
Ø14,5

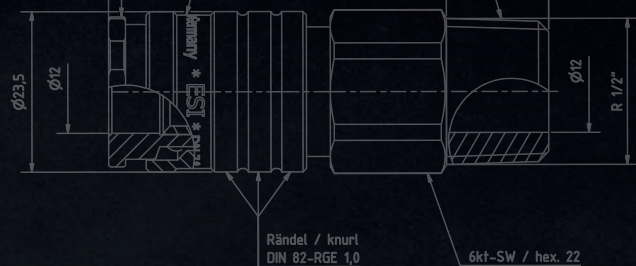

Sicherheitsverriegelung /
safety interlock

(1 : 1)

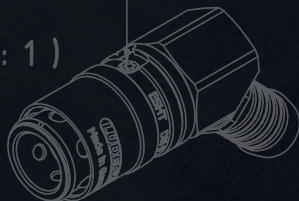

Hülse Messing vernickelt - freier Durchgang
sleeve brass nickel plated - free passage

Material:

Körper; Ventil - Messing

Hülse - Messing

Federn - 1.4310 (AISI301)

O-Ring - FKM

material:

body; valve - brass

sleeve - brass

spring - 1.4310 (AISI301)

seal - FKM

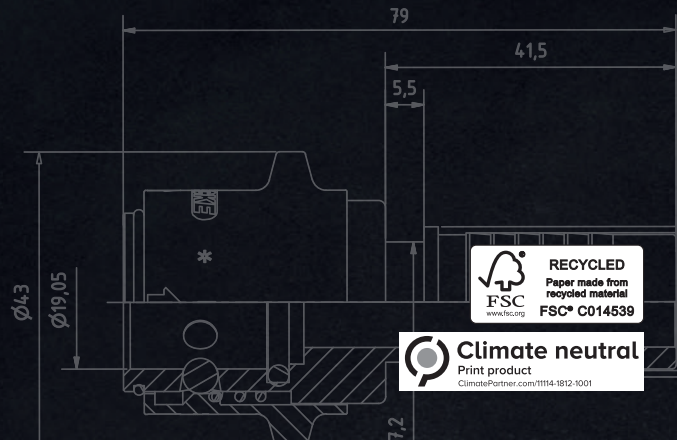

LUDECKE GmbH - Heinrich-Hauck-Str. 2 · D-92224 Amberg

Phone: +49 9621 76820 · Fax: +49 9621 768299

info@luedecke.de - www.luedecke.com

